

ANL H 021-203

Reversible air/water heat pump

Cooling capacity 5,7 ÷ 49,1 kW
Heating capacity 6,2 ÷ 43,3 kW

- It is possible to produce hot domestic water
- Compact dimensions



EUROVENT LCP

DESCRIPTION

Reversible air/water heat pump for air conditioning systems with cold water production for cooling rooms and hot water for heating and/or domestic hot water services, suitable for connection with small or medium users.

Equipped with scroll compressors, axial fans, external coil with aluminium fins, plate heat exchanger on the side.

The base structure and the panels are made of steel treated with polyester paint RAL 9003.

VERSIONS

° Standard

A With storage tank and pump

N With increased pump

P With pump

Q With storage tank and increased pump

FEATURES

Operating field

Full load up to 46 ° C ambient air temperature with the possibility to produce chilled water down to -10° C in cooling mode (for more details refer to the technical documentation).

Version with Integrated hydronic kit

Integrated hydronic kit containing the main hydraulic components; available with various configurations to obtain a solution that allows you to facilitate installation.

Inverter fans

Inverter fans from size 031 to 091 for all sizes.

■ The DCPX accessory is not required for these sizes.

MODUCONTROL CONTROL

The command panel of the unit allows the rapid setting of the working parameters of the machine, and their visualisation. The display consists of 4 figures and various LEDs for indicating the type of operational

mode, the visualisation of the parameters set and of any alarms triggered. The card stores all the default settings and any modifications.

ACCESSORIES

MODU-485BL: RS-485 interface for supervision systems with MODBUS protocol.

MULTICONTROL: Allows the simultaneous control of several units (up to 4), fitted with our MODUCONTROL controller, installed in the same hydraulic system.

PR3: Simplified remote panel. This makes it possible to carry out the unit's basic controls with the signalling of alarms. Can be made remote with shielded cable up to 150 m.

SDHW: Domestic hot water sensor. To be used with a storage tank for the control of water temperature produced.

SPLW: System water temperature sensor. In most cases the loose supplied sensors for each chiller/heat pump are sufficient. In cases of a common flow/return header this sensor can be used to control the common system supply water temperature for the chillers connected to the header, or it can be used for temperature monitoring

VMF-CRP: To predict accessory for the management of the probes SPLW / SDHW if provided with the MULTICONTROL

DCPX: Device for condensation temperature control, with continuous speed modulation of fans by using a pressure transducer.

VT: Antivibration supports

BDX: Condensate drip.

FACTORY FITTED ACCESSORIES

DRE: Electronic device for peak current reduction.

RA: Anti-freeze electric heater for the buffer tank.

KR: Anti-freeze electric heater for the plate heat exchanger.

KRB: Electric anti-freeze resistance kit for base.

COMPATIBILITY WITH VMF SYSTEM

For more information about VMF system, refer to the dedicated documentation.

ACCESSORIES COMPATIBILITY

Accessories

Model	Ver	021	026	031	041	051	071	081	091	103	153	203
MODU-485BL	°A,P	*	*	*	*	*	*	*	*	*	*	*
	N									*	*	*
	Q					*	*	*	*	*	*	*
MULTICONTROL	°A,P	*	*	*	*	*	*	*	*	*	*	*
	N									*	*	*
	Q					*	*	*	*	*	*	*
PR3	°A,P	*	*	*	*	*	*	*	*	*	*	*
	N									*	*	*
	Q					*	*	*	*	*	*	*
SDHW (1)	°A,P	*	*	*	*	*	*	*	*	*	*	*
	N									*	*	*
	Q					*	*	*	*	*	*	*
SPLW (2)	°A,P	*	*	*	*	*	*	*	*	*	*	*
	N									*	*	*
	Q					*	*	*	*	*	*	*
VMF-CRP	°A,P	*	*	*	*	*	*	*	*	*	*	*
	N									*	*	*
	Q					*	*	*	*	*	*	*

- (1) Probe required for MULTICONTROL for managing the domestic hot water system.
(2) Probe required for MULTICONTROL to manage the secondary circuit system.

DCPX: Condensation control temperature

Ver	021	026	031	041	051	071	081	091	103	153	203
°A,P	DCPX51	DCPX51	-	-	-	-	-	-	DCPX53	DCPX53	DCPX53

The accessory cannot be fitted on the configurations indicated with -

Antivibration

Ver	021	026	031	041	051	071	081	091	103	153	203
°P	VT9	VT9	VT9	VT9	VT9	VT9	VT9	VT9	VT15	VT15	VT15
A	VT9	VT9	VT9	VT9	VT15	VT15	VT15	VT15	VT15	VT15	VT15
N	-	-	-	-	-	-	-	-	VT15	VT15	VT15
Q	-	-	-	-	VT15	VT15	VT15	VT15	VT15	VT15	VT15

The accessory cannot be fitted on the configurations indicated with -

Condensate drip

Ver	021	026	031	041	051	071	081	091	103	153	203
°A,P	BDX5	BDX5	BDX5	BDX5	BDX5	BDX5	BDX5	BDX5	-	-	-
Q	-	-	-	-	BDX6	BDX6	BDX6	BDX6	-	-	-

The accessory cannot be fitted on the configurations indicated with -

DRE: Device for peak current reduction

Ver	021	026	031	041	051	071	081	091	103	153	203
°A,P,Q	-	-	-	-	DRES (1)	DRES (1)	DRES (1)	DRES (1)	DRES x 2 (1)	DRES x 2 (1)	DRES x 2 (1)
N	-	-	-	-	-	-	-	-	DRES x 2 (1)	DRES x 2 (1)	DRES x 2 (1)

- (1) Only for supplies of 400V 3N ~ 50Hz and 400V 3 ~ 50Hz. x 2 or x 3 (if present) indicates the quantity to be ordered.

The accessory cannot be fitted on the configurations indicated with -
A grey background indicates the accessory must be assembled in the factory

KR: electric heater for the heat exchanger

Ver	021	026	031	041	051	071	081	091	103	153	203
°P	KR2	KR2	KR2	KR2	KR2	KR2	KR2	KR2	KR100	KR100	KR100
A	-	-	-	-	KR2	KR2	KR2	KR2	KR100	KR100	KR100
N,Q	-	-	-	-	-	-	-	-	KR100	KR100	KR100

The accessory cannot be fitted on the configurations indicated with -
A grey background indicates the accessory must be assembled in the factory

RA: Anti-freeze electric heater for the buffer tank

Ver	021	026	031	041	051	071	081	091	103	153	203
A	RA	RA	RA	RA	RA	RA	RA	RA	RA100	RA100	RA100
Q	-	-	-	-	RA	RA	RA	RA	RA100	RA100	RA100

The accessory cannot be fitted on the configurations indicated with -
A grey background indicates the accessory must be assembled in the factory

KRB: Electric heater for the base

Ver	021	026	031	041	051	071	081	091	103	153	203
°A,N,P,Q	-	-	-	-	-	-	-	-	KRB3 (1)	KRB3 (1)	KRB3 (1)

- (1) Incompatible with the condensate collection basin accessory with integrated resistance.
The accessory cannot be fitted on the configurations indicated with -
A grey background indicates the accessory must be assembled in the factory

CONFIGURATOR

Field	Description
1,2,3	ANL
4,5,6	Size 021, 026, 031, 041, 051, 071, 081, 091, 103, 153, 203
7	Model
H	Heat pump
8	Version
°	Standard
A	With storage tank and pump
N	With increased pump (1)
P	With pump
Q	With storage tank and increased pump (2)
9	Heat recovery
°	Without heat recovery
D	With desuperheater (3)
10	Coils
°	Rame - alluminio
R	Copper-copper
S	Copper-Tinned copper
V	Copper-painted aluminium
11	Operating field
°	Standard mechanic thermostatic valve
12	Evaporator
°	Standard
13	Power supply
°	400V 3N ~ 50Hz (4)
M	230V ~ 50Hz (5)

(1) Only for ANL 103 ÷ 203 sizes

(2) Only for ANL 051 ÷ 203 sizes

(3) The desuperheater must be intercepted during heating mode. During cooling mode the temperature of the water in the heat exchanger inlet must never drop below 35°C. It is only available in sizes from 051 to 091 in the version with storage tank "A", and from size 103 to 203 in all versions.

(4) Only for ANL 021 ÷ 203 sizes

(5) Only for ANL 021 ÷ 041 sizes

PERFORMANCE SPECIFICATIONS 12 °C / 7 °C - 40 °C / 45 °C

ANL - (H°) - (400V 3N ~ 50Hz / 230V ~ 50Hz)

Size		021	026	031	041	051	071	081	091	103	153	203
Cooling performance 12 °C / 7 °C (1)												
Cooling capacity	kW	5,7	6,2	7,5	9,6	13,3	16,3	20,0	21,5	25,5	31,7	40,2
Input power	kW	1,9	2,0	2,5	3,3	4,4	5,9	6,7	6,7	9,2	11,0	14,1
Cooling total input current - 400V	A	3,7	4,2	4,7	6,2	8,7	9,7	12,0	13,0	16,0	19,0	25,0
Cooling total input current - 230V	A	6,4	7,3	8,1	11,0	-	-	-	-	-	-	-
EER	W/W	3,02	3,02	2,98	2,90	3,06	2,77	3,01	3,21	2,79	2,87	2,85
Water flow rate system side	l/h	979	1065	1289	1649	2294	2807	3452	3713	4398	5467	6929
Pressure drop system side	kPa	30	31	32	30	34	35	44	60	55	57	62
Heating performance 40 °C / 45 °C (2)												
Heating capacity	kW	6,2	7,0	8,4	9,8	13,3	17,4	21,0	22,1	26,2	35,5	42,0
Input power	kW	1,9	2,2	2,7	3,1	4,1	5,2	6,0	6,4	8,8	11,1	12,7
Heating total input current - 400V	A	3,8	4,4	5,4	6,8	9,5	10,0	13,0	14,0	17,0	19,0	25,0
Heating total input current - 230V	A	6,6	7,6	9,3	12,0	-	-	-	-	-	-	-
COP	W/W	3,21	3,27	3,17	3,22	3,21	3,32	3,49	3,47	2,99	3,21	3,32
Water flow rate system side	l/h	1078	1217	1460	1700	2294	3007	3638	3827	4529	6137	7265
Pressure drop system side	kPa	36	40	41	37	38	39	53	72	70	70	78

(1) Data 14511:2018; System side water heat exchanger 12 °C/7 °C; External air 35 °C
 (2) Data 14511:2018; System side water heat exchanger 40 °C/45 °C; Outside air 7 °C d.b. / 6 °C w.b.

ANL - (HA/HP) - (400V 3N ~ 50Hz / 230V ~ 50Hz)

Size		021	026	031	041	051	071	081	091	103	153	203
Cooling performance 12 °C / 7 °C (1)												
Cooling capacity	kW	5,7	6,2	7,6	9,7	13,4	16,4	20,2	21,7	25,8	32,1	40,6
Input power	kW	1,8	2,0	2,5	3,2	4,3	5,8	6,6	6,6	9,2	11,1	14,2
Cooling total input current - 400V	A	4,0	4,5	5,0	6,6	9,3	10,0	13,0	13,0	17,0	21,0	27,0
Cooling total input current - 230V	A	6,9	7,9	8,7	11,0	-	-	-	-	-	-	-
EER	W/W	3,11	3,12	3,07	2,97	3,11	2,82	3,06	3,29	2,79	2,89	2,87
Water flow rate system side	l/h	979	1065	1289	1649	2294	2807	3452	3713	4398	5467	6929
Useful head system side	kPa	73	73	71	65	76	72	57	52	88	125	111
Heating performance 40 °C / 45 °C (2)												
Heating capacity	kW	6,2	7,0	8,3	9,7	13,1	17,2	20,9	21,9	25,9	35,0	41,5
Input power	kW	1,9	2,1	2,6	3,0	4,1	5,2	5,9	6,3	8,9	11,2	12,7
Heating total input current - 400V	A	4,1	4,7	5,8	7,2	10,0	11,0	14,0	14,0	18,0	21,0	27,0
Heating total input current - 230V	A	7,2	8,2	9,9	12,0	-	-	-	-	-	-	-
COP	W/W	3,23	3,30	3,21	3,25	3,20	3,33	3,51	3,51	2,92	3,14	3,26
Water flow rate system side	l/h	1078	1217	1460	1700	2294	3007	3638	3827	4529	6137	7265
Useful head system side	kPa	68	67	65	58	72	65	46	40	64	94	68

(1) Data 14511:2018; System side water heat exchanger 12 °C/7 °C; External air 35 °C
 (2) Data 14511:2018; System side water heat exchanger 40 °C/45 °C; Outside air 7 °C d.b. / 6 °C w.b.

ANL - (HN/HQ) - (400V 3N ~ 50Hz)

Size		021	026	031	041	051	071	081	091	103	153	203
Cooling performance 12 °C / 7 °C (1)												
Cooling capacity	kW	-	-	-	-	13,5	16,5	20,3	21,8	25,8	32,1	40,6
Input power	kW	-	-	-	-	4,4	5,9	6,7	6,7	9,6	11,4	14,5
Cooling total input current - 400V	A	-	-	-	-	9,7	11,0	13,0	14,0	18,0	21,0	27,0
EER	W/W	-	-	-	-	3,05	2,78	3,03	3,25	2,68	2,82	2,81
Water flow rate system side	l/h	-	-	-	-	2294	2807	3452	3713	4398	5467	6929
Useful head system side - ver. "Q"	kPa	-	-	-	-	160	159	144	140	147	192	170
Useful head system side - ver. "N"	kPa	-	-	-	-	-	-	-	-	147	192	170
Heating performance 40 °C / 45 °C (2)												
Heating capacity	kW	-	-	-	-	13,0	17,1	20,8	21,8	25,9	35,0	41,5
Input power	kW	-	-	-	-	4,2	5,3	6,1	6,4	9,3	11,4	13,0
Heating total input current - 400V	A	-	-	-	-	10,0	11,0	14,0	15,0	19,0	21,0	28,0
COP	W/W	-	-	-	-	3,10	3,24	3,42	3,43	2,78	3,07	3,19
Water flow rate system side	l/h	-	-	-	-	2294	3007	3638	3827	4529	6137	7265
Useful head system side - ver. "Q"	kPa	-	-	-	-	154	151	131	126	107	169	141
Useful head system side - ver. "N"	kPa	-	-	-	-	-	-	-	-	107	169	141

(1) Data 14511:2018; System side water heat exchanger 12 °C/7 °C; External air 35 °C
 (2) Data 14511:2018; System side water heat exchanger 40 °C/45 °C; Outside air 7 °C d.b. / 6 °C w.b.

PERFORMANCE SPECIFICATIONS 23 °C/ 18 °C - 30 °C/ 35 °C

ANL - (H°) - (400V 3N ~ 50Hz / 230V ~ 50Hz)

Size		021	026	031	041	051	071	081	091	103	153	203
Cooling performance 23 °C/ 18 °C (1)												
Cooling capacity	kW	6,9	7,5	9,0	11,6	16,1	19,7	24,2	26,0	30,8	38,3	48,5
Input power	kW	2,0	2,1	2,6	3,4	4,5	6,1	7,0	7,1	9,6	11,6	14,8
Cooling total input current - 400V	A	3,8	4,3	4,9	6,4	9,0	10,0	13,0	13,0	16,0	19,0	26,0
Cooling total input current - 230V	A	6,6	7,6	8,4	11,0	-	-	-	-	-	-	-
EER	W/W	3,50	3,50	3,45	3,36	3,54	3,21	3,47	3,68	3,21	3,31	3,27
Water flow rate system side	l/h	1189	1293	1564	2002	2784	3407	4189	4506	5338	6636	8410
Pressure drop system side	kPa	44	46	47	44	50	52	65	88	81	84	92
Heating performance 30 °C/ 35 °C (2)												
Heating capacity	kW	6,5	7,3	8,8	10,3	13,8	18,1	21,9	23,1	27,3	37,0	43,9
Input power	kW	1,7	1,9	2,3	2,7	3,5	4,7	5,4	5,7	7,8	9,9	11,3
Heating total input current - 400V	A	3,3	3,8	4,6	6,0	8,1	9,1	11,0	12,0	15,0	17,0	22,0
Heating total input current - 230V	A	5,6	6,5	8,0	10,0	-	-	-	-	-	-	-
COP	W/W	3,88	3,96	3,85	3,77	3,90	3,89	4,08	4,05	3,49	3,74	3,87
Water flow rate system side	l/h	1120	1265	1518	1767	2385	3126	3782	3979	4709	6381	7553
Pressure drop system side	kPa	39	43	44	40	41	42	57	78	76	76	84

(1) Data 14511:2018; System side water heat exchanger 23 °C/ 18 °C; External air 35 °C
 (2) Data 14511:2018; System side water heat exchanger 30 °C/ 35 °C; Outside air 7 °C d.b. / 6 °C w.b.

ANL - (HA/HP) - (400V 3N ~ 50Hz / 230V ~ 50Hz)

Size		021	026	031	041	051	071	081	091	103	153	203
Cooling performance 23 °C/ 18 °C (1)												
Cooling capacity	kW	6,9	7,5	9,1	11,7	16,2	19,8	24,4	26,2	31,1	38,8	49,1
Input power	kW	1,9	2,1	2,6	3,4	4,5	6,0	6,9	6,9	9,7	11,6	14,8
Cooling total input current - 400V	A	4,2	4,7	5,2	6,8	9,7	11,0	13,0	14,0	17,0	21,0	28,0
Cooling total input current - 230V	A	7,2	8,2	9,0	12,0	-	-	-	-	-	-	-
EER	W/W	3,63	3,63	3,58	3,46	3,62	3,28	3,55	3,81	3,21	3,36	3,32
Water flow rate system side	l/h	1189	1293	1564	2002	2784	3407	4189	4506	5338	6636	8410
Useful head system side	kPa	63	63	60	51	60	53	31	24	47	63	41
Heating performance 30 °C/ 35 °C (2)												
Heating capacity	kW	6,4	7,3	8,7	10,2	13,7	18,0	21,8	22,9	27,1	36,6	43,3
Input power	kW	1,6	1,8	2,2	2,7	3,5	4,6	5,3	5,6	8,0	10,0	11,4
Heating total input current - 400V	A	3,6	4,1	5,0	6,4	8,8	9,8	12,0	13,0	16,0	19,0	24,0
Heating total input current - 230V	A	6,2	7,1	8,6	11,0	-	-	-	-	-	-	-
COP	W/W	3,93	4,02	3,91	3,81	3,90	3,91	4,11	4,11	3,40	3,67	3,81
Water flow rate system side	l/h	1120	1265	1518	1767	2385	3126	3782	3979	4709	6381	7553
Useful head system side	kPa	67	64	62	55	69	61	41	34	55	81	53

(1) Data 14511:2018; System side water heat exchanger 23 °C/ 18 °C; External air 35 °C
 (2) Data 14511:2018; System side water heat exchanger 30 °C/ 35 °C; Outside air 7 °C d.b. / 6 °C w.b.

ANL - (HN/HQ) - (400V 3N ~ 50Hz)

Size		021	026	031	041	051	071	081	091	103	153	203
Cooling performance 23 °C/ 18 °C (1)												
Cooling capacity	kW	-	-	-	-	16,3	19,9	24,5	26,3	31,1	38,7	49,0
Input power	kW	-	-	-	-	4,6	6,2	7,0	7,0	10,2	11,9	15,2
Cooling total input current - 400V	A	-	-	-	-	10,0	11,0	14,0	14,0	18,0	22,0	28,0
EER	W/W	-	-	-	-	3,54	3,23	3,51	3,76	3,07	3,25	3,23
Water flow rate system side	l/h	-	-	-	-	2784	3407	4189	4506	5338	6636	8410
Useful head system side - ver. "Q"	kPa	-	-	-	-	136	135	114	108	79	146	114
Useful head system side - ver. "N"	kPa	-	-	-	-	-	-	-	-	79	146	114
Heating performance 30 °C/ 35 °C (2)												
Heating capacity	kW	-	-	-	-	13,6	17,9	21,7	22,8	27,0	36,6	43,4
Input power	kW	-	-	-	-	3,6	4,7	5,4	5,7	8,4	10,2	11,7
Heating total input current - 400V	A	-	-	-	-	9,1	10,0	13,0	13,0	17,0	19,0	25,0
COP	W/W	-	-	-	-	3,75	3,79	4,00	4,01	3,22	3,57	3,71
Water flow rate system side	l/h	-	-	-	-	2385	3126	3782	3979	4709	6381	7553
Useful head system side - ver. "Q"	kPa	-	-	-	-	149	146	125	119	92	159	129
Useful head system side - ver. "N"	kPa	-	-	-	-	-	-	-	-	92	159	129

(1) Data 14511:2018; System side water heat exchanger 23 °C/ 18 °C; External air 35 °C
 (2) Data 14511:2018; System side water heat exchanger 30 °C/ 35 °C; Outside air 7 °C d.b. / 6 °C w.b.

ENERGY DATA

Size		021	026	031	041	051	071	081	091	103	153	203	
400V 3N ~ 50Hz													
Cooling capacity with low leaving water temp (UE n° 2016/2281)													
SEER	°	W/W	3,13	3,19	3,28	3,34	3,76	3,49	3,80	3,91	3,58	3,74	3,73
	A,P	W/W	3,29	3,36	3,45	3,50	3,89	3,69	3,99	4,16	3,55	3,53	3,55
	N	W/W	-	-	-	-	-	-	-	-	3,14	3,48	3,53
	Q	W/W	-	-	-	-	3,30	3,24	3,53	3,75	3,14	3,48	3,53
ηsc	°	%	122,00	125,00	128,00	131,00	147,00	137,00	149,00	153,00	140,00	146,00	146,00
	A,P	%	129,00	131,00	135,00	137,00	153,00	145,00	157,00	163,00	139,00	138,00	139,00
	N	%	-	-	-	-	-	-	-	-	123,00	136,00	138,00
	Q	%	-	-	-	-	129,00	127,00	138,00	147,00	123,00	136,00	138,00
UE 811/2013 low temperature - Pdesignh ≤ 70 kW (1)													
Pdesignh	°	kW	6,00	6,00	8,00	9,00	13,00	16,00	20,00	21,00	25,00	33,00	40,00
	A,P	kW	6,00	6,00	8,00	9,00	12,00	16,00	20,00	21,00	24,00	33,00	39,00
	N	kW	-	-	-	-	-	-	-	-	24,00	33,00	39,00
	Q	kW	-	-	-	-	12,00	16,00	19,00	21,00	24,00	33,00	39,00
SCOP	°		3,30	3,30	3,33	3,28	3,43	3,43	3,58	3,50	3,53	3,58	3,70
	A,P		3,40	3,40	3,40	3,35	3,48	3,48	3,60	3,53	3,45	3,45	3,60
	N		-	-	-	-	-	-	-	-	3,23	3,35	3,53
	Q		-	-	-	-	3,23	3,28	3,43	3,40	3,23	3,35	3,53
ηsh	°	%	129,00	129,00	130,00	128,00	134,00	134,00	140,00	137,00	138,00	140,00	145,00
	A,P	%	133,00	133,00	133,00	131,00	136,00	136,00	141,00	138,00	135,00	135,00	141,00
	N	%	-	-	-	-	-	-	-	-	126,00	131,00	138,00
	Q	%	-	-	-	-	126,00	128,00	134,00	133,00	126,00	131,00	138,00
Efficiency energy class	°		A+	A+	A+	A+	A+	A+	A+	A+	A+	A++	A++
	A,P		A+	A+	A+	A+	A+	A+	A+	A+	A+	A+	A+
	N		-	-	-	-	-	-	-	-	A+	A+	A+
	Q		-	-	-	-	A+	A+	A+	A+	A+	A+	A+

(1) Efficiencies for low temperature applications (35°C)

ELECTRIC DATA

Size		021	026	031	041	051	071	081	091	103	153	203	
400V 3N ~ 50Hz													
Electric data													
Maximum current (FLA)	°	A	7,0	7,0	7,7	9,7	11,3	13,5	16,3	17,3	22,0	26,0	32,0
	A,P	A	7,7	7,7	8,4	10,4	13,3	15,5	18,3	19,3	23,9	29,1	35,1
	N	A	-	-	-	-	-	-	-	-	26,2	30,2	36,2
	Q	A	-	-	-	-	14,0	13,5	19,0	20,0	26,2	30,2	36,2
Peak current (LRA)	°	A	27,5	33,5	36,7	49,7	65,3	75,3	102,3	96,3	76,0	87,0	117,0
	A,P	A	28,2	34,2	37,4	50,4	67,3	75,3	104,3	98,3	77,9	90,1	120,1
	N	A	-	-	-	-	-	-	-	-	80,2	91,2	121,2
	Q	A	-	-	-	-	68,0	75,3	105,0	99,0	80,2	91,2	121,2
230V ~ 50Hz													
Electric data													
Maximum current (FLA)	°	A	17,5	17,5	20,7	24,7	-	-	-	-	-	-	-
	A,P	A	18,5	18,5	20,5	25,6	-	-	-	-	-	-	-
	N,Q	A	-	-	-	-	-	-	-	-	-	-	-
Peak current (LRA)	°	A	59,5	62,5	83,7	98,7	-	-	-	-	-	-	-
	A,P	A	60,5	63,5	84,5	99,6	-	-	-	-	-	-	-
	N,Q	A	-	-	-	-	-	-	-	-	-	-	-

GENERAL TECHNICAL DATA

Size		021	026	031	041	051	071	081	091	103	153	203
Compressor												
Type	type	Scroll	Scroll	Scroll	Scroll	Scroll	Scroll	Scroll	Scroll	Scroll	Scroll	Scroll
Compressor regulation	Type	On-Off	On-Off	On-Off	On-Off	On-Off	On-Off	On-Off	On-Off	On-Off	On-Off	On-Off
Number	no.	1	1	1	1	1	1	1	1	2	2	2
Circuits	no.	1	1	1	1	1	1	1	1	1	1	1
Refrigerant	type	R410A	R410A	R410A	R410A	R410A	R410A	R410A	R410A	R410A	R410A	R410A
Refrigerant charge	kg	1,8	1,8	2,0	2,0	2,9	2,9	3,1	3,9	4,6	5,4	5,7
System side heat exchanger												
Type	type	Brazed plate	Brazed plate	Brazed plate	Brazed plate	Brazed plate	Brazed plate	Brazed plate	Brazed plate	Brazed plate	Brazed plate	Brazed plate
Number	no.	1	1	1	1	1	1	1	1	1	1	1
Hydraulic connections												
Connections (in/out)	Type	Gas - F	Gas - F	Gas - F	Gas - F	Gas - F	Gas - F	Gas - F	Gas - F	Gas - F	Gas - F	Gas - F
Sizes (in/out)	Ø	1" 1/4	1" 1/4	1" 1/4	1" 1/4	1" 1/4	1" 1/4	1" 1/4	1" 1/4	1" 1/4	1" 1/4	1" 1/4
Fan												
Type	type	Axial	Axial	Axial	Axial	Axial	Axial	Axial	Axial	Axial	Axial	Axial
Fan motor	type	On-Off	On-Off	On-Off	Inverter	Inverter	Inverter	Inverter	Inverter	On-Off	On-Off	On-Off

Size		021	026	031	041	051	071	081	091	103	153	203
Number	no.	1	1	1	1	1	2	2	2	2	2	2
Air flow rate	m ³ /h	2500	2500	3500	3500	7200	7200	7300	7200	14000	13500	13500
Sound data calculated in cooling mode (1)												
Sound power level	dB(A)	61,0	61,0	68,0	68,0	69,0	69,0	69,0	68,0	76,0	77,0	78,0
Sound pressure level (10 m)	dB(A)	29,8	29,8	36,8	36,8	37,6	37,6	37,6	36,6	44,5	45,5	46,5

(1) Sound power calculated on the basis of measurements made in accordance with UNI EN ISO 9614-2, as required for Eurovent certification. Sound pressure (cold functioning) measured in free field, 10m away from the unit external surface (in compliance with UNI EN ISO 3744).

DIMENSIONS

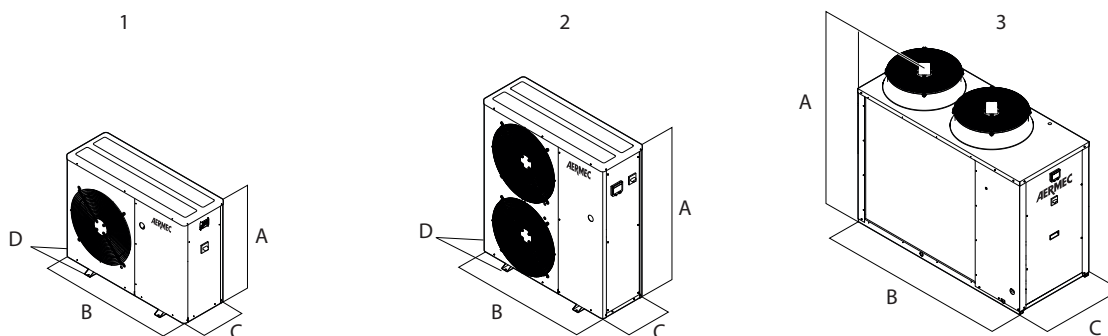

- 1 ANL 021 - 041
- 2 ANL 051 - 091
- 3 ANL 103 - 203

Size			021	026	031	041	051	071	081	091	103	153	203
Dimensions and weights													
A	°P	mm	1000	1000	1000	1000	1252	1252	1252	1252	1450	1450	1450
	A	mm	1015	1015	1015	1015	1281	1281	1281	1281	1450	1450	1450
	N	mm	-	-	-	-	-	-	-	-	1450	1450	1450
	Q	mm	-	-	-	-	1281	1281	1281	1281	1450	1450	1450
B	°P	mm	900	900	900	900	1124	1124	1124	1124	1750	1750	1750
	A	mm	1124	1124	1124	1124	1165	1165	1165	1165	1750	1750	1750
	N	mm	-	-	-	-	-	-	-	-	1750	1750	1750
	Q	mm	-	-	-	-	1165	1165	1165	1165	1750	1750	1750
C	°P	mm	310	310	310	310	384	384	384	384	750	750	750
	A	mm	384	384	384	384	550	550	550	550	750	750	750
	N	mm	-	-	-	-	-	-	-	-	750	750	750
	Q	mm	-	-	-	-	550	550	550	550	750	750	750
D	°P	mm	354	354	354	354	428	428	428	428	-	-	-
	A	mm	428	428	428	428	-	-	-	-	-	-	-
	N	mm	-	-	-	-	-	-	-	-	-	-	-
	Q	mm	-	-	-	-	-	-	-	-	-	-	-
Weight empty	°	kg	86	86	86	86	120	120	120	156	270	293	329
	A	kg	103	103	103	103	147	147	183	183	338	364	400
	N	kg	-	-	-	-	-	-	-	-	338	364	400
	P	kg	91	91	91	91	127	127	163	163	288	314	350
	Q	kg	-	-	-	-	147	147	183	183	338	364	400

Aermec reserves the right to make any modifications deemed necessary. All data is subject to change without notice. Aermec does not assume responsibility or liability for errors or omissions.

Aermec S.p.A.

Via Roma, 996 - 37040 Bevilacqua (VR) - Italia
Tel. 0442633111 - Telefax 044293577
www.aermec.com